

**MODEL: NUM/RB100-SGL-XX-BOT-QD**  
 WHERE "XX" DESIGNATES THE NUMBER OF VALVE STATIONS

REV		CN #	DESCRIPTION	DATE
X1	N/A		DRAWN	02 FEB 00

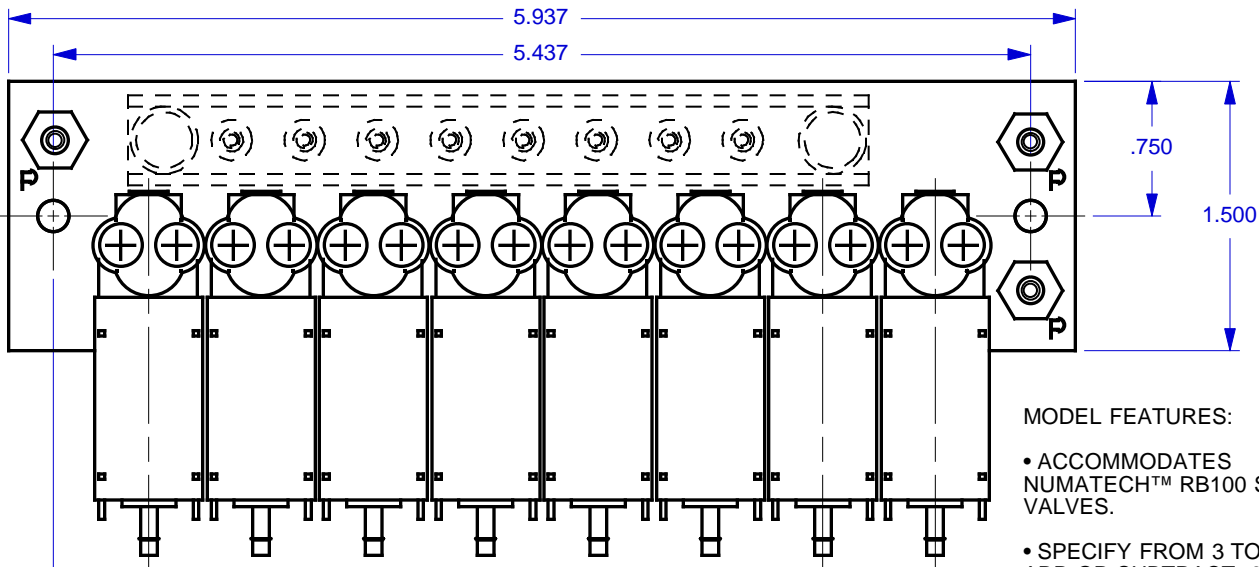

**MODEL FEATURES:**

- ACCOMMODATES NUMATECH™ RB100 SERIES VALVES.
- SPECIFY FROM 3 TO 8 VALVES. ADD OR SUBTRACT .625" (15.87 MM) OF MANIFOLD LENGTH PER VALVE.
- BOTTOM PORTED FOR BEHIND PANEL OR IN-BOX MOUNTING.
- USES EXCLUSIVE MULTIPLE TUBING QUICK-DISCONNECT ASSEMBLY (SOLD SEPARATELY), WHICH INSTALLS OR REMOVES QUICKLY WITH 2 THUMBSCREWS.
- INTERNAL CHANNELS ARE .078" DIAMETER, BRILLIANTLY POLISHED AND WITHSTAND PRESSURE OVER 125 P.S.I.

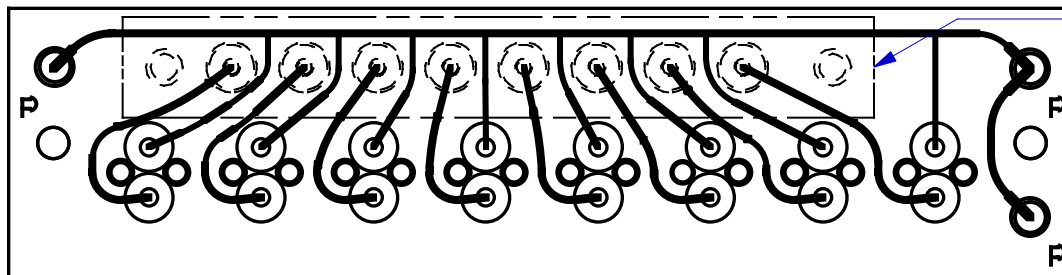
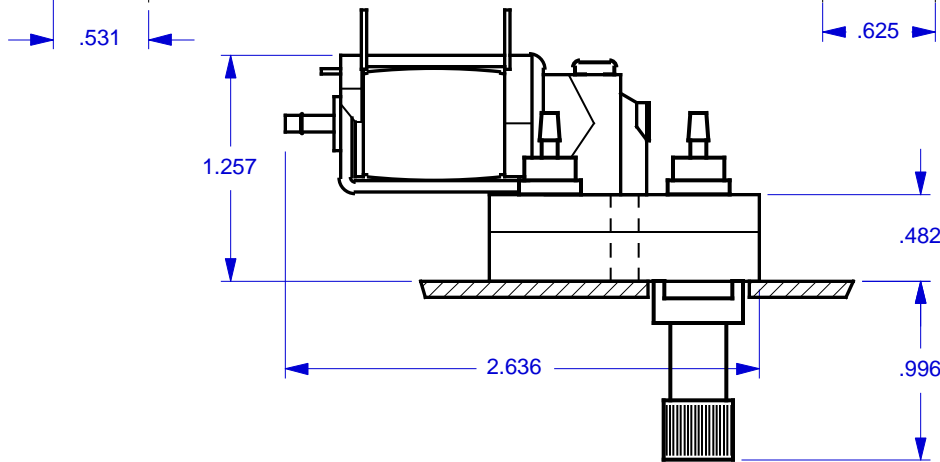

**PANEL CUT-OUT REQD:**  
 .563 H x 4.18 W MIN.  
 RECOMMENDED FOR 8 VALVE MANIFOLD.  
 FOR OTHER MANIFOLDS, ADD OR SUBTRACT .406" (10.3 MM) TO WIDTH PER VALVE

**NOTES:**

1. MANIFOLDS ARE SUPPLIED WITHOUT ANY HARDWARE OR VALVES. THE COMPONENTS SHOWN ARE FOR ILLUSTRATION PURPOSES ONLY.
2. ALL PORTS ARE THREADED #10-32 UNF - 2B. M5.0 THREADS ARE AVAILABLE ON SPECIAL REQUEST.
3. MOUNTING HOLES ARE .156 DIAMETER FOR #6 SCREWS. USE OF .375 DIAMETER X .040 THICK (MIN) NYLON WASHERS UNDER THE MOUNTING SCREW HEADS ARE HIGHLY RECOMMENDED.
4. MANIFOLD MATERIAL IS POLISHED ACRYLIC. CLEAR (BLUISH TINT) P.V.C. IS ALSO AVAILABLE ON SPECIAL ORDER AT INCREASED PRICE.
5. SPECIFICATIONS SUBJECT TO CHANGE WITHOUT NOTICE.

THIS DRAWING AND/OR SPECIFICATION IS THE PROPERTY OF MICROADVANCES, IS ISSUED IN STRICT CONFIDENCE, AND SHALL NOT BE REPRODUCED, COPIED, OR USED AS THE BASIS FOR THE MANUFACTURE OR SALE OF APPARATUS OR COMPONENT PARTS THEREOF WITHOUT PRIOR WRITTEN PERMISSION.

**MicroAdvances**

6073 N.W. 167th STREET, BLDG. C-21  
 MIAMI, FL. USA 33015 • (305) 556-4801

**NAME:** NUM/RB100-SGL-08-BOT-QD  
**PART/DWG NO:** 600280 **REV:** A  
**ASSEMBLY:** N/A  
**DWN BY:** J.W. **DATE:** 02 FEB 00  
**DESIGNED BY:** XX  
**REF:** NUM/RB100

NUMATECH, INC., Wixom, MI 48393

**SCALE:** 1 : 1 @ 7.9 X 10.4 **SHEET:** 1 OF 1