

MODEL: FST - MZBH3 - SGL.XX - BOT.QD
 WHERE "XX" DESIGNATES THE NUMBER OF VALVE STATIONS

| REV | | CN # | | DESCRIPTION | DATE |
|-----|-----|------|--|-------------|-----------|
| X1 | N/A | | | DRAWN | 20 MAR 99 |

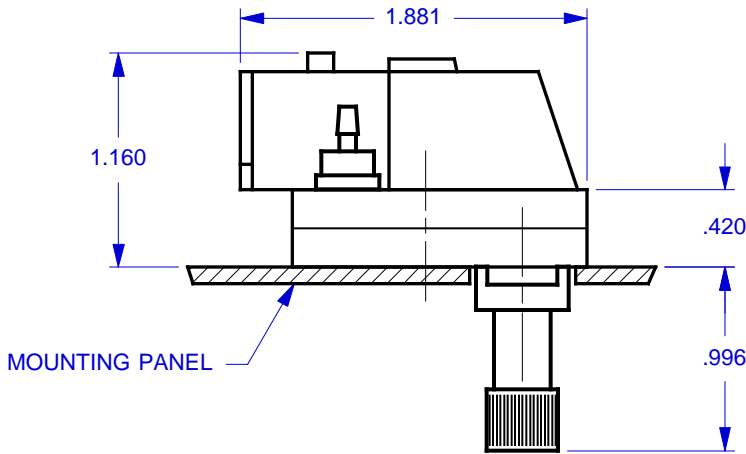
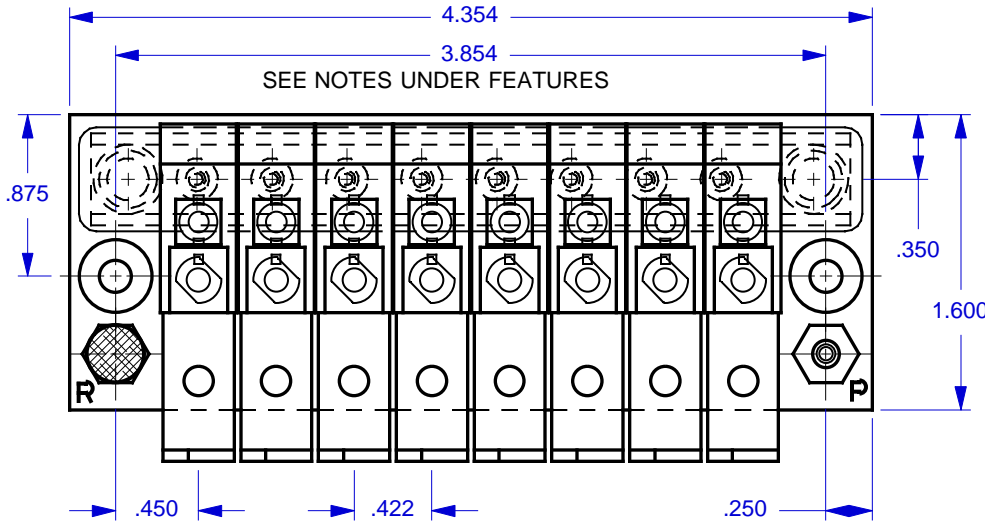

MODEL FEATURES:

- ACCOMMODATES FESTO™ MZBH 3 - WAY MINIATURE AIR VALVES.
- SPECIFY FROM 3 TO 12 VALVES. ADD OR SUBTRACT .422" (10.72 MM) OF MANIFOLD LENGTH PER VALVE.
- BOTTOM PORTED FOR BEHIND PANEL OR IN-BOX MOUNTING.
- USES EXCLUSIVE MULTIPLE TUBING QUICK-DISCONNECT ASSEMBLY (SOLD SEPARATELY), WHICH INSTALLS / REMOVES QUICKLY WITH 2 THUMBSCREWS.
- VALVES ARE MOUNTED WITH SPECIALLY DESIGNED TAPPED HOLES TO ACCOMMODATE THIS VALVE'S SPECIAL MTG. SCREWS .
- THREADED EXHAUST "R" AND PRESSURE "P" PORTS ARE TOP PORTED.
- "P1" (PRESSURE) AND "P2" (OUTPUT) CHANNELS ARE .047" DIA. "P3" (EXHAUST) CHANNEL IS .040".
- INTERNAL CHANNELS AND THREADS ARE BRILLIANTLY POLISHED AND WITHSTAND PRESSURE OVER 125 P.S.I.

PANEL CUT-OUT REQD:
 .563 H X 4.250 W RECOMMENDED
 SEE NOTE 2 ABOVE

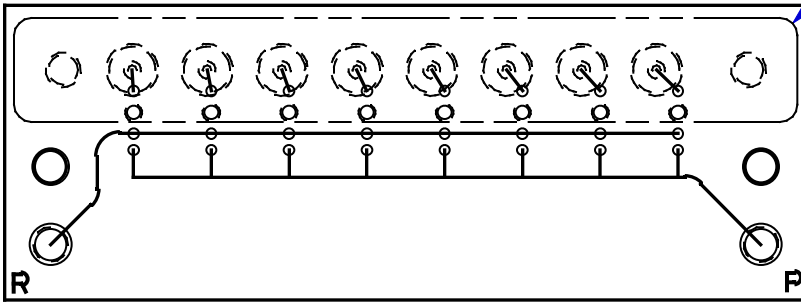

NOTES:

1. MANIFOLDS ARE SUPPLIED WITHOUT ANY HARDWARE OR VALVES. THE COMPONENTS SHOWN ARE FOR ILLUSTRATION PURPOSES ONLY.
2. ALL PORTS ARE THREADED #10-32 UNF - 2B. M5.0 THREADS ARE AVAILABLE ON SPECIAL REQUEST.
3. MOUNTING HOLES ARE .156 DIAMETER FOR #6 SCREWS. USE OF .375 DIAMETER X .040 THICK (MIN) NYLON WASHERS UNDER THE MOUNTING SCREW HEADS ARE HIGHLY RECOMMENDED.
4. MANIFOLD MATERIAL IS POLISHED ACRYLIC. CLEAR (BLUISH TINT) P.V.C. IS ALSO AVAILABLE ON SPECIAL ORDER AT INCREASED PRICE.
5. SPECIFICATIONS SUBJECT TO CHANGE WITHOUT NOTICE.

THIS DRAWING AND/OR SPECIFICATION IS THE PROPERTY OF MICROADVANCES, IS ISSUED IN STRICT CONFIDENCE, AND SHALL NOT BE REPRODUCED, COPIED, OR USED AS THE BASIS FOR THE MANUFACTURE OR SALE OF APPARATUS OR COMPONENT PARTS THEREOF WITHOUT PRIOR WRITTEN PERMISSION.

MicroAdvances

6073 N.W. 167th STREET, BLDG. C-21
 MIAMI, FL. USA 33015 • (305) 556-4801

NAME: FST-MZBH3-SGL.08-BOT.QD
PART/DWG NO: 600242 **REV:** X1
ASSEMBLY: N/A
DWN BY: J.W. **DATE:** 20 MAR 99
DESIGNED BY: XX
REF: XX

SCALE: 1 : 1 @ 7.9 X 10.4 **SHEET:** 1 OF 1